

NOVA

Inverter warranty





**SUSIDŪRUS SU PRIETAISŲ SUTRIKIM AIS,
NEDVEJODAMI KREIPKITĖS Į MUS.**

El. paštas: novasupport@solitek.eu

**IF YOU ENCOUNTER ANY ISSUES WITH
YOUR PURCHASED PRODUCTS, DON'T
HESITATE TO REACH OUT TO US.**

Email: novasupport@solitek.eu

**WENN SIE PROBLEME MIT IHREN GEKAUF TEN
PRODUKTEN HABEN, ZÖGERN SIE NICHT,
UNS ZU KONTAKTIEREN.**

E-Mail: novasupport@solitek.eu

**SE RICONTRI PROBLEMI CON I PRODOTTI
ACQUISTATI, NON ESITARE A CONTATTARCI.**

E-mail: novasupport@solitek.eu

— Turinys

Produkto garantija

LT

Gamintojas.....	6
Garantijos sąlygos.....	6
Solitek Energy garantinis aptarnavimas.....	8
Transporto sąnaudų padengimas.....	8
Kita svarbi informacija.....	9

— Content

Product warranty

EN

Manufacturer.....	10
Warranty Terms.....	10
Solitek Energy after-sales service.....	12
Cover transport costs.....	12
Other important information.....	13

— Inhalt

Produktgarantie

DE

Hersteller.....	14
Garantiebedingungen.....	14
Solitek Energy Kundendienst.....	16
Transportkosten Übernahme.....	16
Weitere wichtige Informationen.....	17

— Contenuto

Garanzia sul prodotto

IT

Produttore.....	18
Termini di garanzia.....	18
Servizio post-vendita di Solitek Energy.....	20
Costi di trasporto.....	20
Altre informazioni importanti.....	21

Produkto garantija

GAMINTOJAS: SoliTek Energy

GARANTIJOS SĄLYGOS:

Ši garantija taikoma šiems SoliTek Inverter serijos produktams:

Produkto kodas
SoliTek NOVA 5K Inverter (single-phase)
SoliTek NOVA 8K Inverter (single-phase)
SoliTek NOVA 5K Inverter (three-phase)
SoliTek NOVA 6K Inverter (three-phase)
SoliTek NOVA 8K Inverter (three-phase)
SoliTek NOVA 10K Inverter (three-phase)
SoliTek NOVA 12K Inverter (three-phase)



Ši garantija apima visas valstybes ir regionus.



Garantinio aptarnavimo paslaugos teikiamos tik pateikus produkto Serijinį Numerį (S/N). Garantijos terminas yra 10 metų nuo pirkimo datos.



Išsisaugokite originalią pirkimo sąskaitą-faktūrą arba produkto pirkimo-pardavimo aktą. Vieną iš jų reikia pateikti norint gauti garantinį aptarnavimą arba atlikti produkto keitimą.



Pirkėjas gali susisiekti su SoliTek Energy telefonu ir el. paštu. Norėdamas gauti garantinį aptarnavimą, pirkėjas turi pateikti šią informaciją:

- Produkto modelio kodą ir S/N (serijinis numeris);
- Produkto sistemos konfigūraciją (modulių kiekis grandinėse, grandinių kiekis, grandinių schema, el. tinklo rūšis, įtampa ir dažnis);
- Sutrikimo aprašą (sistemos sutrikimo kodo, rodomo ekranelyje, nuotrauka).

SoliTek Energy pasilieka teisę atsisakyti suteikti garantinį aptarnavimą, jeigu nepateikiama aukščiau išvardinta informacija.



Nemokamas garantinis aptarnavimas suteikiamas produktams su galiojančia garantija. Garantija panaikinama, kai:

- Pažeidžiami garantiniai lipdukai be SoliTek Energy sutikimo;
- Produktas pažeidžiamas trečiajam šaliai jį transportuojant;
- Produktas neteisingai įrengtas arba neteisingai eksploatuojamas, pvz.: neteisingai sujungtos AC fazės arba neteisingai sujungti DC poliai;
- Nesilaikoma produkto naudojimosi instrukcijose keliamų reikalavimų produkto įrengimui ir priežiūrai;
- Pirkėjas be SoliTek Energy leidimo atlieka pakeitimus arba taisymą;
- Nėra užtikrinamas reikiamas įrenginio vėdinimas;
- Nesilaikoma saugumo reikalavimų;
- *Force majeure*, t.y. nuo SoliTek nepriklausančios aplinkybės (karas, gamtos stichijos ir pan.);



Produktams, kuriems nebetaikomas garantinis aptarnavimas, SoliTek Energy apmokestina aptarnavimo paslaugas.

SOLITEK ENERGY GARANTINIS APTARNAVIMAS

Garantinio aptarnavimo
kontaktinis elektroninis paštas:
novasupport@solitek.eu

Produktams taikomos garantinės paslaugos:

Produktų serija	Garantinė paslauga	Garantinis periodas
SoliTek Inverter	Garantinio aptarnavimo pagalba telefonu ar el. paštu	10 metų
	Garantinio aptarnavimo pagalba išsiunčiant atstovą į įrengimo vietą	10 metų
	Garantinis inverterio ar jo dalių keitimas	10 metų



Įrengimas: SoliTek Energy neatlieka inverterių įrengimo paslaugas.

TRANSPORTO SĄNAUDŲ PADENGIMAS



SoliTek Energy apsiima padengti transporto sąnaudas garantijoje nurodytiems produktams. Pirkėjas apsiima padengti išmuitinimo sąnaudas.

Pirkėjas apsiima padengti ir transporto, ir išmuitinimo sąnaudas produktams, kurių garantinis terminas yra pasibaigęs.

KITA SVARBI INFORMACIJA



Šiame dokumente pateiktos sąlygos nusako visas SoliTek Energy atsakomybes Jūsų įsigytiems produktams. Be formalaus patvirtinimo raštu, SoliTek Energy atsakomybės išlieka tik tos, kurios aprašytos šiame dokumente. Jeigu produktas yra eksploatuojamas ir turi galiojančią garantiją, SoliTek Energy atsakomybes apibrėžia produkto garantinio aptarnavimo paslaugų sąrašas.



SoliTek Energy pasilieka galutinę šio produkto garantijos dokumento interpretacijos teisę.

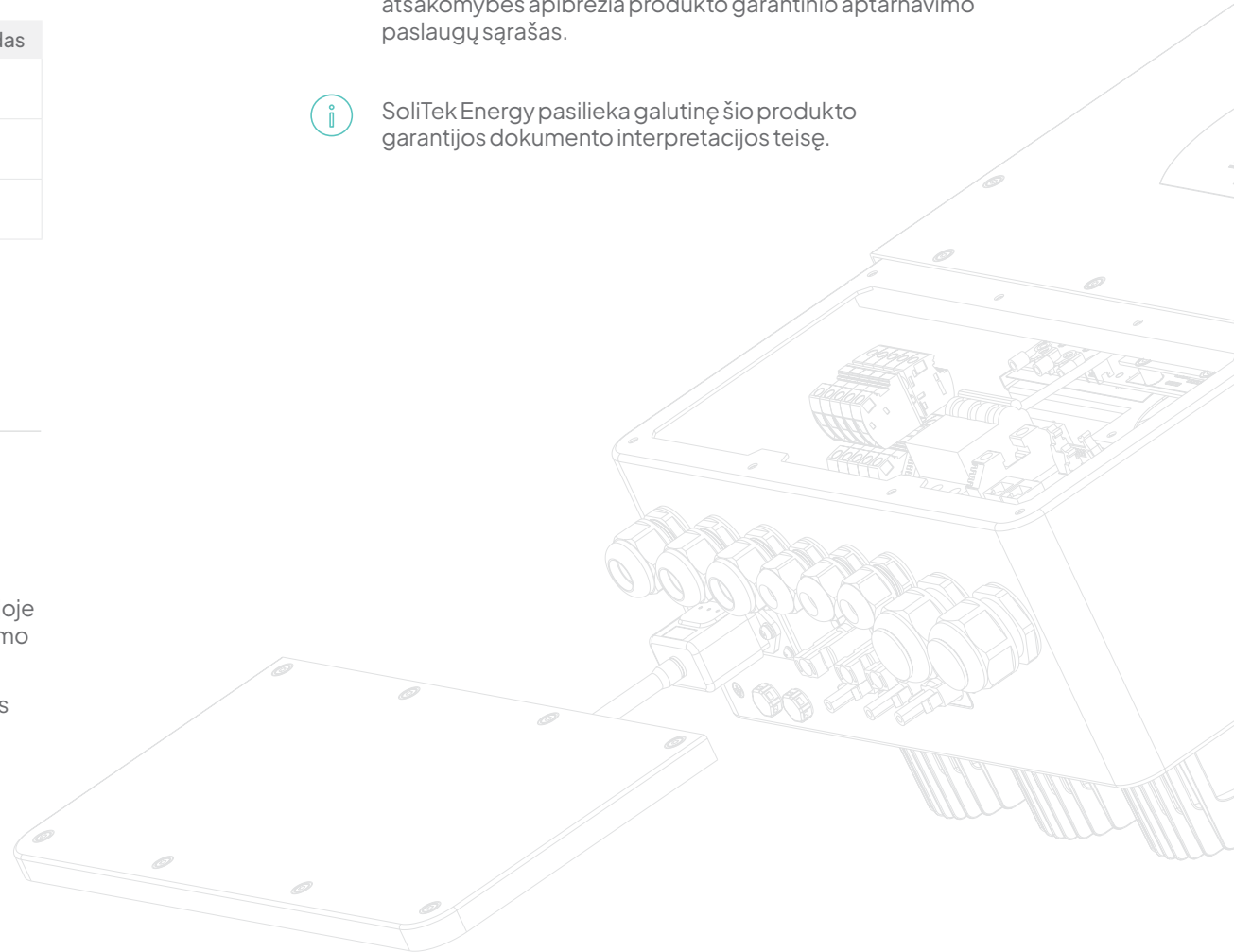

Product warranty

MANUFACTURER: SoliTek Energy

WARRANTY TERMS:

This warranty covers the following SoliTek Inverter Series products:

Product code
SoliTek NOVA 5K Inverter (single-phase)
SoliTek NOVA 8K Inverter (single-phase)
SoliTek NOVA 5K Inverter (three-phase)
SoliTek NOVA 6K Inverter (three-phase)
SoliTek NOVA 8K Inverter (three-phase)
SoliTek NOVA 10K Inverter (three-phase)
SoliTek NOVA 12K Inverter (three-phase)



This Warranty covers all countries and regions.



Warranty service is available only upon presentation of the product Serial Number (S/N). The warranty period is 10 years from the date of purchase.



Retain the original purchase invoice or bill of sale for the product. One of these must be presented in order to obtain warranty service or product replacement.



The Buyer can contact SoliTek Energy by phone and email. To obtain after-sales service, the Buyer must provide the following information:

- Product model code and S/N (serial number);
- Product system configuration (number of modules in the circuits, number of circuits, circuit diagram, type of electrical network, voltage and frequency);
- A description of the fault (picture of the system fault code displayed on the screen).

SoliTek Energy reserves the right to refuse to provide warranty service if the above-mentioned information is not provided.



Free after-sales service is provided for products with a valid warranty. The warranty is voided when:

- Warranty stickers are damaged without the consent of SoliTek Energy;
- There is damage to the product during transportation by a third party;
- The product is incorrectly installed or operated, e.g. AC phases are incorrectly connected or DC poles are incorrectly connected;
- Failed to comply with the installation and maintenance requirements of the product's instructions for use;
- The Customer makes alterations or repairs to the product without the authorisation of SoliTek Energy;
- Failed to ensure adequate ventilation of the installation;
- Failed to comply with safety requirements;
- *Force majeure*, (i.e. circumstances beyond SoliTek's control (war, natural disasters, etc.);



For products that are out of warranty, SoliTek Energy charges for service.

SOLITEK ENERGY AFTER-SALES SERVICE

Warranty Service contact email:

novasupport@solitek.eu

Warranty services for products:

Product series	Warranty service	Warranty period
SoliTek Inverter	Warranty support by phone or email	10 years
	Warranty support by sending a representative to the installation site	10 years
	Warranty replacement of the inverter or parts	10 years



Installation: SoliTek Energy does not provide an inverter installation service.

COVER TRANSPORT COSTS



SoliTek Energy undertakes to cover the transport costs for the products covered by the guarantee. The Buyer undertakes to bear the cost of customs clearance.

The Buyer undertakes to pay both transport and customs clearance costs for products that have exceeded their warranty period.

OTHER IMPORTANT INFORMATION



The terms outlined in this document define all of SoliTek Energy's responsibilities for your purchased products. Without formal written confirmation, SoliTek Energy's liability is limited solely to those described in this document. If a product is in operation and has an active warranty, SoliTek Energy's responsibilities are defined by the list of warranty service offerings for the product.



SoliTek Energy reserves the final right of interpretation of this product warranty document.

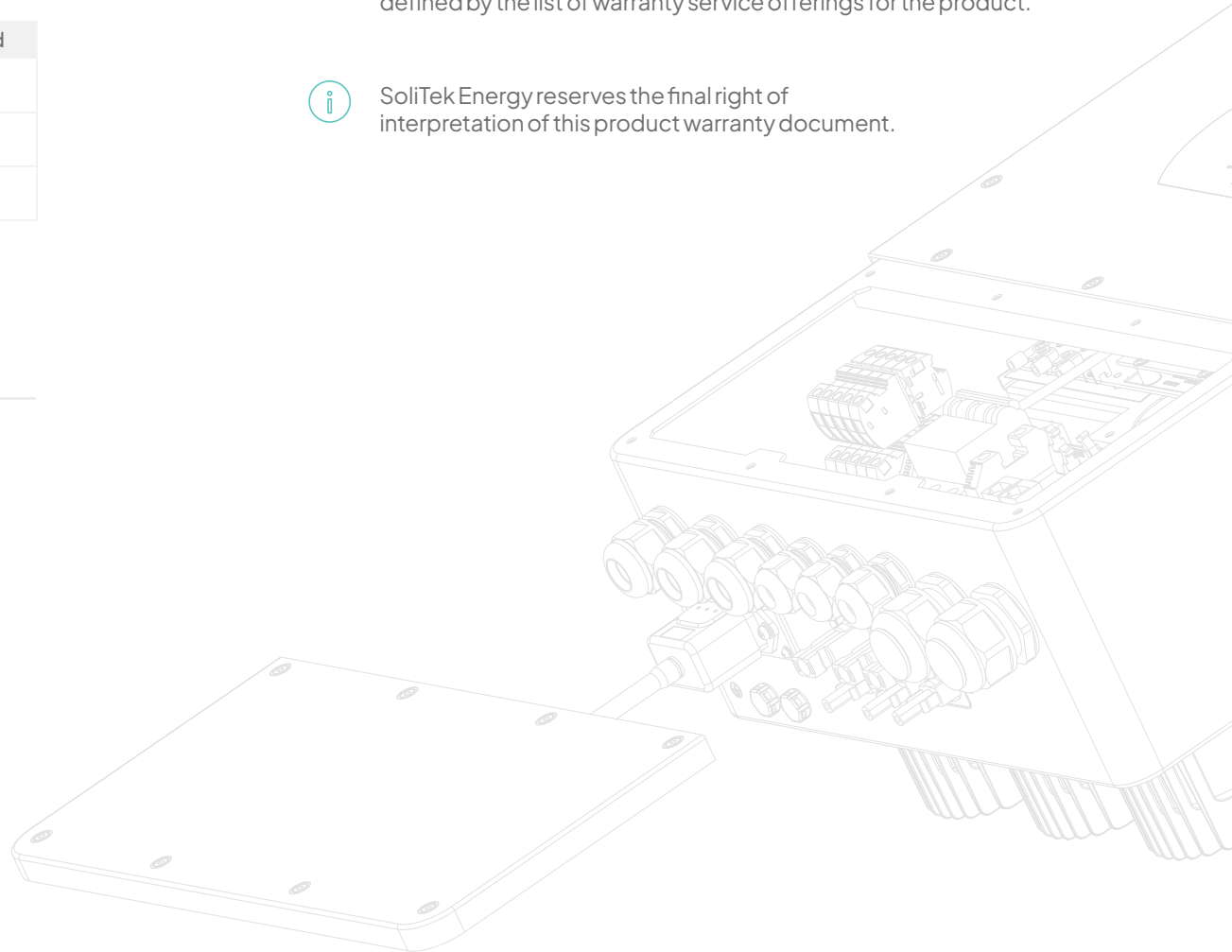

Produktgarantie

HERSTELLER: SoliTek Energy

GARANTIEBEDINGUNGEN:

Diese Garantie deckt die folgenden Produkte der SoliTek Inverter Serie ab:

Produktcode
SoliTekNOVA 5K Inverter (single-phase)
SoliTekNOVA 8K Inverter (single-phase)
SoliTekNOVA 5K Inverter (three-phase)
SoliTekNOVA 6K Inverter (three-phase)
SoliTekNOVA 8K Inverter (three-phase)
SoliTekNOVA 10K Inverter (three-phase)
SoliTekNOVA 12K Inverter (three-phase)



Diese Garantie gilt für alle Länder und Regionen.



Der Garantieservice ist nur bei Vorlage der Seriennummer (S/N) des Produktes erhältlich. Die Garantiezeit beträgt 10 Jahre ab dem Kaufdatum.



Bewahren Sie die Originalrechnung oder den Kaufbeleg für das Produkt auf. Eines davon muss vorgelegt werden, um Garantieleistungen oder den Austausch des Produktes zu erhalten.



Der Käufer kann SoliTek Energy per Telefon und E-Mail kontaktieren. Um den Kundendienst in Anspruch zu nehmen, muss der Käufer die folgenden Informationen bereitstellen:

- Produktmodellcode und S/N (seriennummer);
- Systemkonfiguration des Produkts (Anzahl der Module in den Schaltkreisen, Anzahl der Schaltkreise, Schaltplan, Art des Stromnetzes, Spannung und Frequenz);
- Eine Beschreibung des Fehlers (Bild des auf dem Bildschirm angezeigten Systemfehlercodes).

SoliTek Energy behält sich das Recht vor, die Garantieleistung zu verweigern, wenn die oben beschriebenen Informationen nicht bereitgestellt werden.



Kostenloser Kundendienst wird für Produkte mit einer gültigen Garantie angeboten. Die Garantie erlischt, wenn:

- Garantiesiegel ohne Zustimmung von SoliTek Energy beschädigt wurden;
- Das Produkt während des Transports durch Dritte beschädigt wurde;
- Das Produkt falsch installiert oder betrieben wurde, z.B. AC-Phasen sind falsch angeschlossen oder DC-Pole sind falsch angeschlossen;
- Die Installations- und Wartungsanforderungen der Gebrauchsanweisung des Produkts nicht eingehalten wurden;
- Der Kunde Änderungen oder Reparaturen am Produkt ohne die Autorisierung von SoliTek Energy vorgenommen hat;
- Nicht für ausreichende Belüftung bei der Installation gesorgt wurde;
- Sicherheitsanforderungen nicht eingehalten wurden;
- *Höhere Gewalt*, d.h. Umstände, die außerhalb von SoliTek's Kontrolle liegen (Krieg, Naturkatastrophen, etc.);



Für Produkte, die nicht mehr unter Garantie stehen, stellt SoliTek Energy den Service in Rechnung.

SOLITEK ENERGY KUNDENDIENST

**Kontakt-E-Mail für den
Garantieservice:**
novasupport@solitek.eu

Garantieleistungen für Produkte:

Produkt-Serie	Garantieservice	Garanziezeitraum
SoliTek Inverter	Garantieunterstützung per Telefon oder E-Mail	10 Jahre
	Garantieunterstützung durch Entsendung eines Vertreters zum Installationsort	10 Jahre
	Austausch des Wechselrichters oder von Teilen im Rahmen der Garantie	10 Jahre



Installation: SoliTek Energy bietet keinen
Wechselrichter-Installationservice an.

TRANSPORTKOSTEN ÜBERNAHME



SoliTek Energy verpflichtet sich, die Transportkosten für die von
der Garantie abgedeckten Produkte zu übernehmen. Der Käufer
verpflichtet sich, die Zollabfertigungskosten zu tragen.

Der Käufer übernimmt sowohl die Transport- als auch die
Zollabfertigungskosten für Produkte, die ihre Garantiezeit
überschritten haben.

WEITERE WICHTIGE INFORMATIONEN



Die in diesem Dokument enthaltenen Bedingungen und Konditionen
skizzieren alle Verantwortlichkeiten von SoliTek Energy in Bezug
auf verkaufte Produkte. Ohne formelle schriftliche Bestätigung
bleiben die Verantwortlichkeiten von SoliTek Energy auf die in diesem
Dokument beschriebenen beschränkt. Wenn das Produkt im Service
ist und eine gültige Garantie hat, werden die Verantwortlichkeiten von
SoliTek Energy in der Produktgarantieserviceliste definiert.



SoliTek Energy behält sich das
endgültige Auslegungsrecht dieses
Produktgarantiedokuments vor.

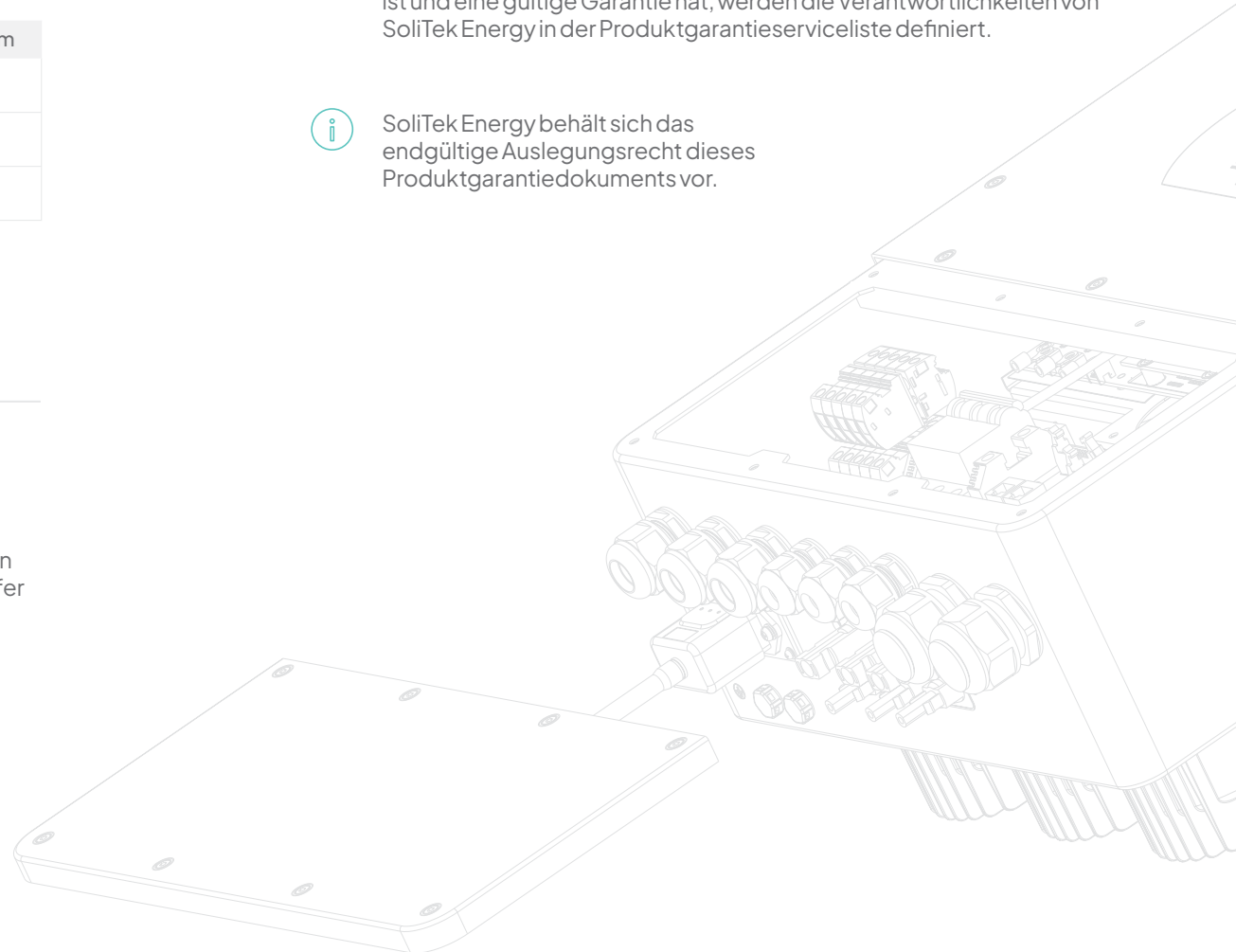

Garanzia sul prodotto

PRODUTTORE: SoliTek Energy

TERMINI DI GARANZIA:

La presente garanzia copre i seguenti prodotti della serie SoliTek Inverter:

Codice prodotto
SoliTekNOVA 5K Inverter (single-phase)
SoliTekNOVA 8K Inverter (single-phase)
SoliTekNOVA 5K Inverter (three-phase)
SoliTekNOVA 6K Inverter (three-phase)
SoliTekNOVA 8K Inverter (three-phase)
SoliTekNOVA 10K Inverter (three-phase)
SoliTekNOVA 12K Inverter (three-phase)



La presente garanzia copre tutti i paesi e le regioni.



Il servizio di garanzia è disponibile solo dietro presentazione del numero di serie del prodotto (S/N). Il periodo di garanzia è di 10 anni dalla data di acquisto.



Conservare la fattura d'acquisto originale o la fattura di vendita del prodotto. Per ottenere l'assistenza in garanzia o la sostituzione del prodotto, è necessario presentare uno di questi documenti.



L'Acquirente può contattare SoliTek Energy per telefono e per e-mail. Per ottenere l'assistenza post-vendita, l'Acquirente deve fornire le seguenti informazioni:

- Codice modello e S/N (numero di serie) del prodotto;
- Configurazione del sistema del prodotto (numero di moduli nei circuiti, numero di circuiti, schema elettrico, tipo di rete elettrica, tensione e frequenza);
- Descrizione del guasto (immagine del codice di guasto del sistema visualizzato sullo schermo).

SoliTek Energy si riserva il servizio di garanzia se le informazioni di cui sopra non vengono fornite.



L'assistenza post-vendita è gratuita per i prodotti con garanzia valida. La garanzia decade quando:

- Gli adesivi di garanzia vengono danneggiati senza il consenso di SoliTek Energy;
- Il prodotto viene danneggiato durante il trasporto da parte di terzi;
- Il prodotto è installato o utilizzato in modo errato, ad esempio le fasi AC sono collegate in modo errato o i poli DC sono collegati in modo errato;
- Non sono stati rispettati i requisiti di installazione e manutenzione delle istruzioni per l'uso del prodotto;
- Il Cliente apporta modifiche o riparazioni al prodotto senza l'autorizzazione di SoliTek Energy;
- Non si è riusciti a garantire un'adeguata ventilazione dell'impianto;
- Non sono stati rispettati i requisiti di sicurezza;
- *Forza maggiore*, ovvero circostanze al di fuori del controllo di SoliTek (guerre, disastri naturali, ecc.);



Per i prodotti fuori garanzia, SoliTek Energy addebita il costo dell'assistenza.

SERVIZIO POST-VENDITA DI SOLITEK ENERGY:

E-mail di contatto del servizio di garanzia:

novasupport@solitek.eu

Servizi di garanzia per i prodotti:

Serie di prodotti	Servizio di garanzia	Periodo di garanzia
SoliTek Inverter	Assistenza in garanzia via telefono o e-mail	10 anni
	Assistenza in garanzia tramite l'invio di un rappresentante sul luogo di installazione	10 anni
	Sostituzione in garanzia dell'inverter o delle parti	10 anni



Installazione: SoliTek Energy non fornisce un servizio di installazione dell'inverter.

COSTI DI TRASPORTO:



SoliTek Energy si impegna a coprire le spese di trasporto dei prodotti coperti da garanzia. L'Acquirente si impegna a sostenere le spese di sdoganamento.

L'Acquirente si impegna a sostenere le spese di trasporto e di sdoganamento per i prodotti non coperti da garanzia.

ALTRE INFORMAZIONI IMPORTANTI:



I termini e le condizioni contenuti in questo documento delineano tutte le responsabilità di SoliTek Energy in relazione ai prodotti venduti. Senza una conferma formale scritta, le responsabilità di SoliTek Energy rimangono limitate a quelle descritte nel presente documento. Se il prodotto è in servizio e ha una garanzia valida, le responsabilità di SoliTek Energy sono definite dall'Elenco dei servizi di garanzia del prodotto.



SoliTek Energy si riserva il diritto di interpretazione finale del presente documento di garanzia del prodotto.

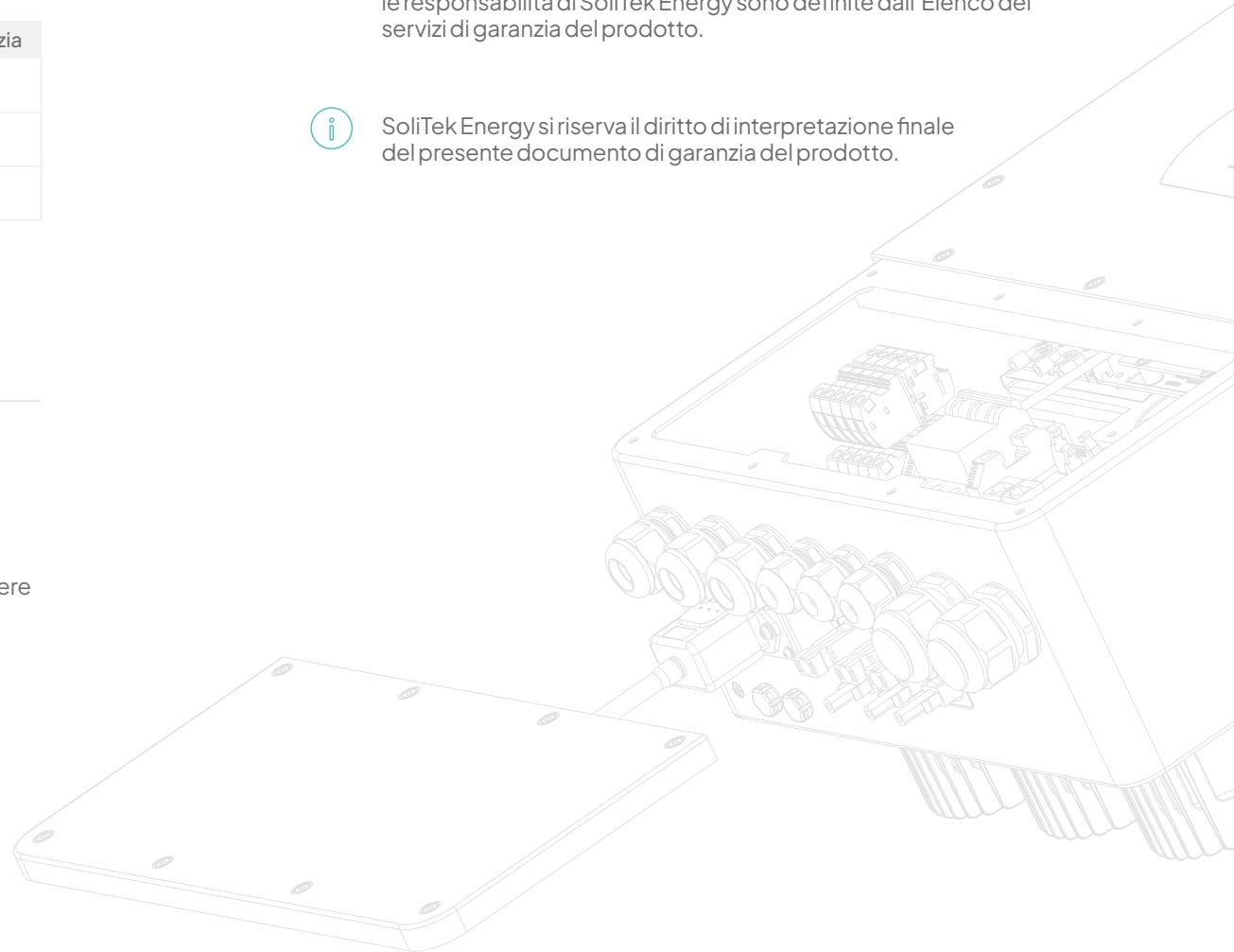

**WE HAD A SPARE PAGE LEFT
SO HERE'S SOME WORD SEARCH**

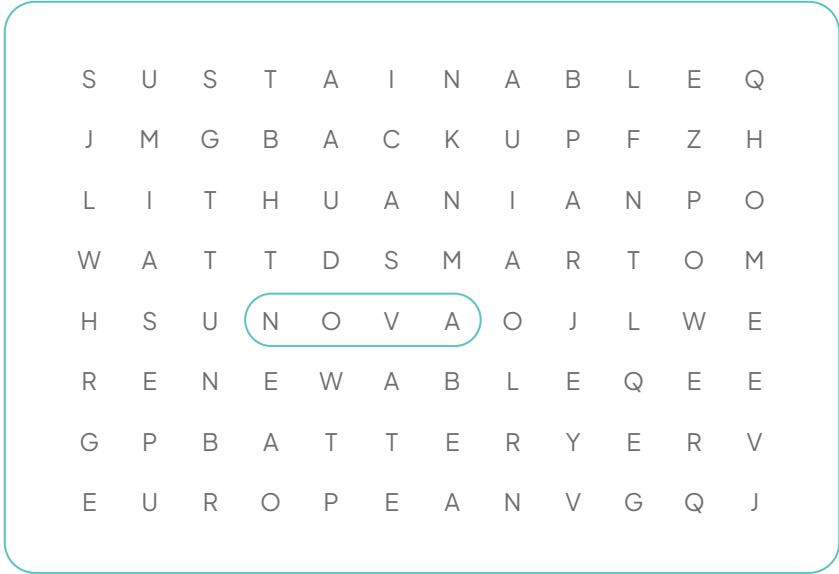

Find the following words in the puzzle.

Words are hidden → and ↓.

-
- | | | |
|----------|-----------------|-------------|
| BACKUP | LITHUANIAN | SMART |
| BATTERY | NOVA | SUN |
| EUROPEAN | POWER | SUSTAINABLE |
| HOME | RENEWABLE | WATT |

The background features a light gray line-art illustration of industrial machinery. At the top, a control panel with various knobs and a 'BATTERY' label is visible. Below it, a large rectangular unit with a ribbed base is shown. In the lower-left corner, a component with 'LOAD' and 'GEN' labels and several circular ports is depicted. A cable connects this component to a flat, rectangular metal plate with four circular mounting holes, which is positioned in the lower-right area.

**Energy
for all your
needs**